

EC Series

GMS1000C

— **Generator Set Specification**

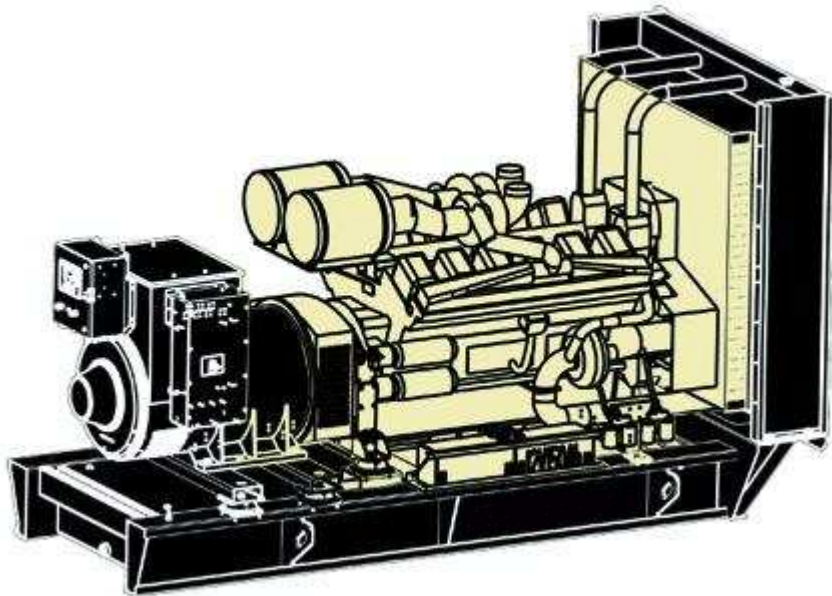

Your Partner for Power...

GMS1000C

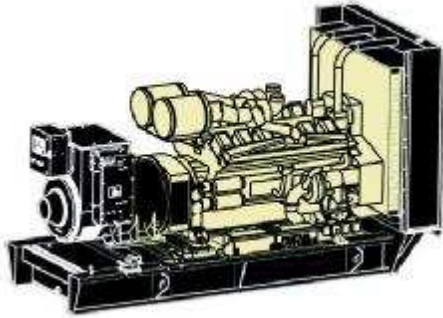

3-Phase, 50Hz@1500RPM				
	Voltage	kW	kVA	Amps
Prime Power	380	800	1000	1519.4
	400	800	1000	1443.4
	415	800	1000	1391.2
	440	800	1000	1312.2
Standby Power	380	888.9	1111.1	1688.2
	400	888.9	1111.1	1603.8
	415	888.9	1111.1	1545.8
	440	888.9	1111.1	1458.0
Noise Level at 7 meters (dBA)			100.3	

Notes:

- 1) Ambient reference conditions: 1,000 mbar, 27°C, 30% relative humidity;
- 2) Standby Power: the maximum power available under varying loads. Only for standby and emergency use. No overload is permissible. Prime Power: the maximum power available under varying loads for continuous operation. A 10% overload is permissible for 1 hour every 12 hours.

Features	Benefits
<ul style="list-style-type: none"> I Tightly structure, excellent design and craft I Designed with safety in mind I Earth leakage protection I Quick fix electrical power connections I Extensive option list 	<ul style="list-style-type: none"> I Beautiful appearance I Low operating cost results in optimal economy I Ease of installation, operation, and maintenance I Customization I Good quality ensure

Performance Specification and Craftwork

Performance Specification		Telephone Interference, Electromagnetism	
Efficiency of Rated Power	96.3%	TIF	≤50
Time needed from start-up to full load (inductive)	125 seconds	THF	≤2%
Time needed from start-up to 50% load (inductive) allowed	8 seconds	Radio interference in compliance with BS800 and VED LEVELS G and N.	
1.1 times overload operation time (hour)	1	Craftwork <ul style="list-style-type: none"> • Steel base frame with AV mounting • standard 8h fuel tank with flexible rubber fuel tube, fuel level indicator and drainage • Overall sprayed powder coating • Whole set documents, including Installation Manual, Operation Manual, Spare Parts Catalog, Circuit Diagram Criterion <ul style="list-style-type: none"> • ISO3046, ISO8528, BS4999, BS5514, • BS5000PT99、AS1359, IEC34 • UTE5100, VDE0530 • ISO9001:2000 	
2.0 time overload operation time (minute)	1		
Voltage Regulation, steady state	≤±1%		
Voltage Regulation, transient state	20%-15%		
Voltage Settle Time	≤5 seconds		
Voltage Fluctuation Ratio	0.5%		
Frequency Regulation, steady state	±0.5% adjustable		
Frequency Regulation, transient state	±5%		
Frequency Settle Time	5 seconds		
Frequency Fluctuation Ratio	0.5%		
Recovery Time	0.5 seconds		

GMS1000C

Engine Specification			Alternator Specification		
Brand	Cummins		Brand	Stamford	
Model	KTA38G5		Model	LVI634E	
No. of Cylinders and Cycle	12V, 4 Stroke		Rated Output (kVA)	1000	
Induction System	TCA		Rated current (A)	1443.4	
Compression Ratio	13.9: 1		Exciter	Brushless	
Displacement (L)	37.8		THF (BS EN60034- 1)	<2%	
Bore x Stroke (mm)	159 x 159		Bearing number	Single	
Net weight (kg)	3723		Windings	100% Copper	
Piston speed (m/s)	7.9		Connection Type	Star Connection	
Intake Air Flow (L/s)	1140		Insulation Class	H	
Exhaust gas temperature (°C)	499		Winding Pitch	2/3	
Exhaust gas flow (L/s)	3051		Amortisseur Winding	Full	
Base Output power (kW)	880		A.V.R. Model	MX321	
RPM	1500		Voltage Regulation (no load- full load)	± 0.5%	
Brake mean effective pressure (kPA)	1868		Underspeed Protection	Standard	
			Protection	IP23	
Fuel Consumption (L/h)	110% load		Phase Sequence	A(U), B(V), C(W)	
	100% load	209	TIF (NEMA MG 1-22)	<50	
	75% load	161	Excitation System	Self-excited, PMG optional	
	50% load	113	Ambient Temp. (°C)	40	
Governor Type	E		Stator Rated Temp. (°C)	125	

Cooling System			Fuel System		
Max. coolant friction head external to engine (kPA)	55		Type injection System	Direct injection	
Thermostat adjusting temperature (°C)	104/100		Fuel rail pressure (kPA)	22	
Min. opening pressure of radiator cap (kPA)	69				
Coolant capacity-engine only (L)	124				
Exhaust System			Lubricating System		
Max. Back Pressure (kPA)	10.1		Total system capacity (L)	135	
Electrical System			Oil pressure		
Starter (V)	24		Rated speed (kPA)	310-448	
Battery charging system (A)	35				

GMS1000C

Control System

PLC-702

DSE-702 key manual start module is a manual engine control module designed to control the engine via a key switch and push buttons on the front panel. The module is used to start and stop the engine and indicate fault conditions, automatically shutting down the engine and giving a true first up fault condition of an engine failure.



Standard Control Function

- Manual Engine Control Module
- Low Oil Pressure
- High Engine Temperature
- Auxiliary Shutdown
- Overspeed Protection
- Protection hold-off timer
- Charge Failure warning

PLC-5220

DSE-5220 control pannel is applied

- | Microprocessor control, with high stability and credibility
- | Mains supply and generator operation monitoring
- | Indicating operation status and fault conditions
- | Multiple protections; multiple parameters display, like pressure, temp.
- | Manual and automatic work mode selectable
- | Real time clock for time and date display, overall runtime display, 99 log entries
- | Overall power output display
- | Integral speed/frequency detecting, telling status of start, rated operation, overspeed
- | Communication with PC via RS485 OR RS232 interface, using MODBUS protocol.



Dimension and Weight

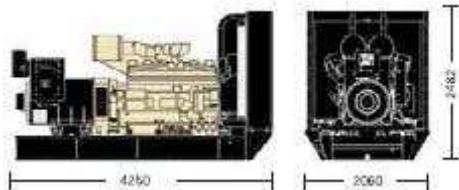

GMS1000C

Length × Width × Height, mm
4250×2060×2482

Weight (kg):
8000

GMS1000C

Optional

Engine	Alternator	Generator Set	Fuel System	Canopy
<ul style="list-style-type: none"> • Coolant heater 	<ul style="list-style-type: none"> • Space heater • AVR PMG with regulator • Anti-damp and anti-corrosion treatment • Anti-condensation heater 	<ul style="list-style-type: none"> • Tools with the machine 	<ul style="list-style-type: none"> • Low fuel level alarm • Automatic fuel feeding system 	<ul style="list-style-type: none"> • Container
Lubricating System	Exhaust System	Cooling System	Control Panel	Voltages
<ul style="list-style-type: none"> • Oil with the machine 	<ul style="list-style-type: none"> • Protection board from hotness • Low frequency silencer 	<ul style="list-style-type: none"> • Front heat protection • 50°C radiator • Coolant (-30°C) 	<ul style="list-style-type: none"> • Remote control panel • Automatic paralleling control panel • Automatic Transfer Switch (ATS) 	<ul style="list-style-type: none"> • 415/240V • 400/230V • 380/220V • 220/127V • 200-115V



Local Distributor